

Specifications

CK-SMFA230-S08

Industrial Imaging Lens

Features

- Designed for machine vision applications
- Support 10MP pixel camera, maximum target surface 2/3"
- A variety of focal lengths to choose from, adjustable aperture
- High definition, high contrast, low distortion, excellent performance
- Each lens has been rigorously tested to ensure constant quality

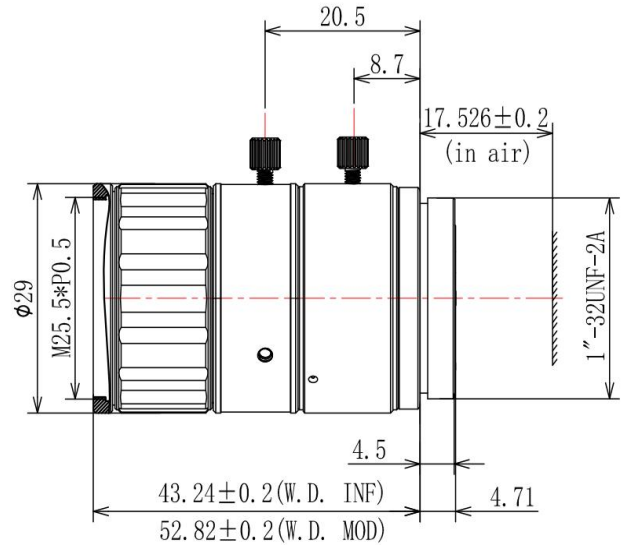

2/3" F2.6/16 C-Mount				
Focal length		f=8mm		
Aperture range		F=2.6~16		
Camera chip size		1/1.8"	1/2"	2/3"
Field of view	H	56.5°	42.0°	53.5°
	V	34.1°	32.1°	46°
	D	56.5°	51.4°	67.2°
TV distortion		<0.5%		
Closest distance MOD		0.11m		
Maximum target size		Φ11.4mm		
Filter thread size		M27xP0.5		
interface		C-Mount		