

# CK-SMFA230-S12

## Specifications

## Industrial Imaging Lens

### Features

- Designed for machine vision applications
- Support 10MP pixel camera, maximum target surface 2/3"
- A variety of focal lengths to choose from, adjustable aperture
- High definition, high contrast, low distortion, excellent performance
- Each lens has been rigorously tested to ensure constant quality

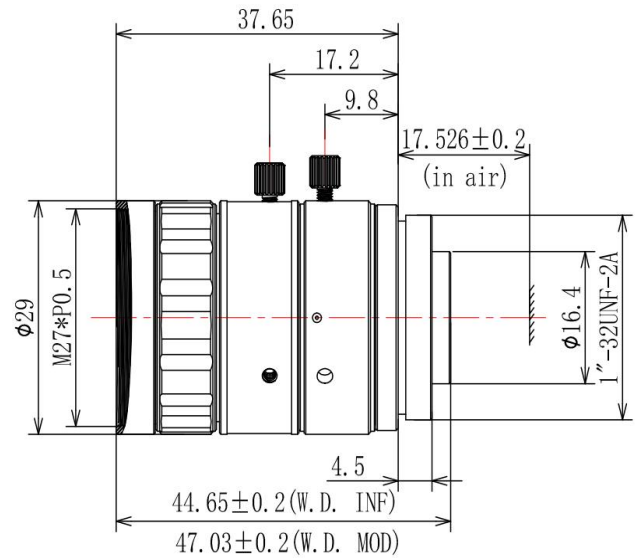

2/3" F2.0/16 C-Mount				
Focal length		f=12mm		
Aperture range		F=2.0~16		
Camera chip size		1/1.8"	1/2"	2/3"
Field of view	H	33.1°	29.0°	39.7°
	V	22.3°	21.9°	27.5°
	D	39.7°	35.8°	48.1°
TV distortion		<0.5%		
Closest distance MOD		0.11m		
Maximum target size		Φ11.4mm		
Filter thread size		M27xP0.5		
Interface		C-Mount		