

# Specifications

# CK-SMFA230-S25

## Industrial Imaging Lens

### Features

- Designed for Machine Vision Applications
- Support 10MP pixel camera, the maximum target area is 2/3"
- A variety of focal lengths are available and the aperture is adjustable
- High definition, high contrast, low distortion, excellent performance
- Each lens has been strictly tested to ensure consistent quality

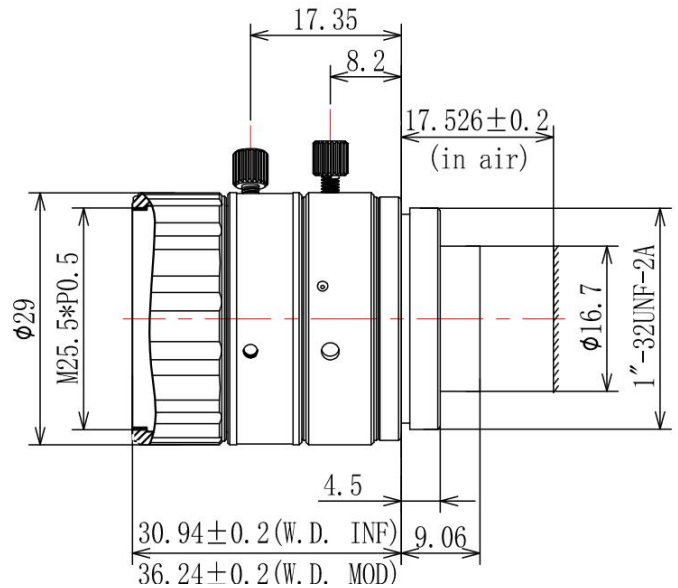

2/3" F2.0/16 C-Mount				
Focal length		f=25mm		
Aperture range		F=2.0~16		
Camera chip size		1/1.8"	1/2"	2/3"
Field of view	H	15.8°	14°	18.3°
	V	10.7°	10.5°	15.4°
	D	19.4°	17.4°	23.9°
TV distortion		<0.1%		
Closest distance MOD		0.2m		
Maximum target size		Φ11.4mm		
Filter thread size		M27xP0.5		
Interface		C-Mount		