

Specifications

CK-SMFA230-S35

Industrial Imaging Lens

Features

- Designed for machine vision applications
- Support 10MP pixel camera, maximum target surface 2/3"
- A variety of focal lengths to choose from, adjustable aperture
- High definition, high contrast, low distortion, excellent performance
- Each lens has been rigorously tested to ensure constant quality

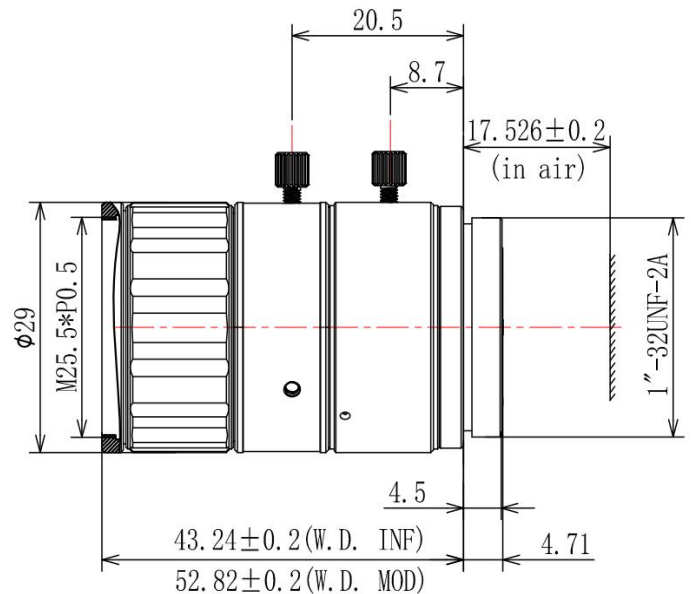

| 2/3" F2.0/16 C-Mount | | | | |
|----------------------|----------|--------|-------|--------|
| Focal length | f=35mm | | | |
| Aperture range | F=2.0~16 | | | |
| Camera chip size | 1/1.8" | 1/2" | 2/3" | |
| Field of view | H | 11.7° | 9.6° | 12.8° |
| | V | 7.4° | 7.2° | 10.7° |
| | D | 13.45° | 12.1° | 16.49° |
| TV distortion | <0.1% | | | |
| Closest distance MOD | 0.2m | | | |
| Maximum target size | Φ11.4mm | | | |
| Filter thread size | M27xP0.5 | | | |
| Interface | C-Mount | | | |