

CK-SWWK0367-220-110

Specification

High-performance object-oriented telecentric lens

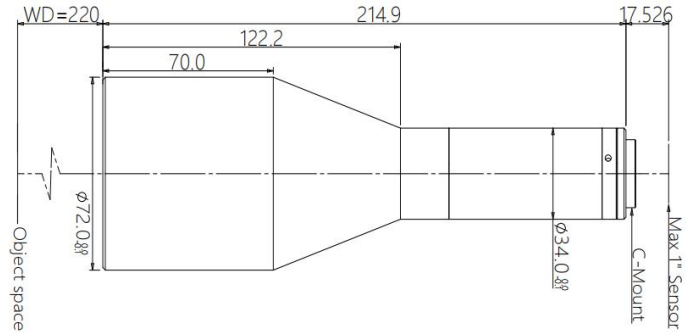

Features

- Support high-resolution object-oriented telecentric lenses for 5M~20M pixel area scan cameras;
- A variety of low magnification designs to adapt to application scenarios with a larger field of view;
- High definition, low distortion, high telecentric, especially suitable for high-precision AOI and positioning applications;
- Long working distance specifications facilitate lighting and machine component layout;
- Built-in coaxial optical specifications are particularly suitable for wafers, glass devices, and display devices;
- Can be quickly customized to meet different camera specifications, as well as magnification, working distance, and depth of field requirements.

Optical parameters

Magnification $\beta(x)$	0.367
Working distance (mm)	220 \pm 3
CCD size (Φ mm)	16.0(1")
F/#	8
MTF30 (lp/mm)	>115
Object Depth of Field DoF(mm)	\pm 2.4@F8
Image distortion (% max)	<0.1
Telecentricity ($^{\circ}$ max)	<0.1

Mechanical parameters

Camera interface	C
Overall lens length (mm)	214.9
Whether the coaxial light	No

Viewable range (mm x mm)

1" PYTHON 5000 (12.43x9.83)	33.9x26.8
1" IMX255 (14.19x7.51)	38.7x20.5
1" IMX183 (13.13x8.76)	35.8x23.9