

CK-RNE2-304M/CU-56GS

3 MP CMOS USB3.0 Area Scan Camera

Features

- The Sequencer Control supports multiple sets of parameters configuration
- Decimation, Binning, Digital Shift and Black Level
- Adjustable Gamma for optimizing the brightness of images
- Color models support Light Source Preset, Color Transformation Control and Saturation
- Monochrome models support Noise Reduction and Sharpness
- Timer, Counter, LUTs and User Set Control
- 16KB data storage area for saving algorithm coefficients and parameter configuration
- 512KB ROM area for storing large amounts of data and files

Applications

Suitable for machine vision applications such as industrial inspection, medical, scientific research, education and so on.

I/O Interface



Pin	Definition	Description
1	Line0+	Opto-isolated input +
2	GND	GPIO GND
3	Line0-	Opto-isolated input -
4	NC	NC
5	Line2	GPIO input/output
6	Line3	GPIO input/output
7	Line1-	Opto-isolated output -
8	Line1+	Opto-isolated output +

Models

Mono: CK-RNE2-304MU-56GS

Color: CK-RNE2-304CU-56GS



Spectral Response

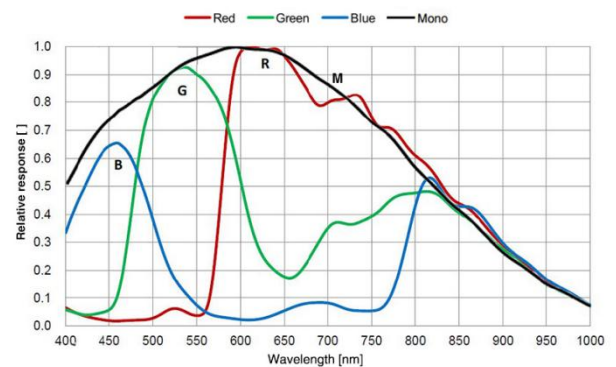

Technical Drawing

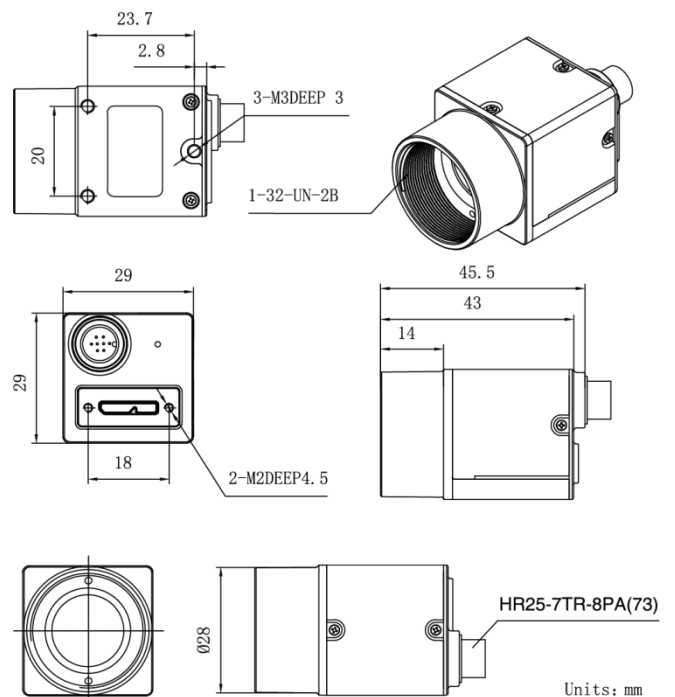

Specifications

Model	CK-RNE2-304CU-56GS	CK-RNE2-304MU-56GS
Resolution	2048(H) × 1536(V)	
Sensor	Sony Global shutter CMOS	
Sensor Format	1/1.8"	
Pixel Size	3.45μm × 3.45μm	
Frame Rate	56.2 fps	
ADC	12 bit	
Pixel Bit Depth	8 bit, 12 bit	
Mono/Color	Color	Mono
Pixel Formats	Bayer RG8 / Bayer RG12	Mono8 / Mono12
SNR	40.56 dB	40.62 dB
Exposure Time	UltraShort: 1μs~100μs, Actual Steps: 1 μs; Standard: 20μs ~ 1s, Actual Steps: 1 row period	
Gain	0dB ~ 24dB; Default: 0dB, Steps: 0.1dB	
Binning	FPGA: 1×1, 1×2, 1×4, 2×1, 2×2, 2×4, 4×1, 4×2, 4×4 Sensor: 1×1, 2×2	
Decimation	FPGA: 1×1, 1×2, 1×4, 2×1, 2×2, 2×4, 4×1, 4×2, 4×4	
Synchronization	Hardware trigger , software trigger	
Acquisition Mode	Single frame, Continuous, Software trigger, Hardware trigger	
Reverse X/Y	Reverse X/Y	
I/O Interface	1 input and 1 output with opto-isolated, 2 programmable GPIOs	
Data Interface	USB3.0	
Power Supply	Power through USB3.0 interface	
Typical Power	2.59 W @ 5 VDC	
Operating Temp.	0° C ~ +45° C	
Storage Temp.	-20 ° C~ +70° C	
Operating Humidity	10% ~ 80%	
Lens Mount	C / CS	
Dimensions	29(W) × 29(H) × 45.5(L) mm	
Weight	65 g	
Software	CKVisionBuilder or support USB3 Vision protocol software	
OS	32bit / 64bit Windows , Linux , Android , ARMv7 , ARMv8	

