

CK-RNE2-507MI-23RS-IR

5 MP CMOS GigE Area Scan Camera



Features

- Trigger mode: Frame Start
- Support Gamma, Black Level, LUTs and User Set Control
- Support Remove Parameter Limit to expand the range of exposure, gain, white balance, and so on
- 16KB data storage area for saving algorithm coefficients and parameter configuration

Applications

Suitable for machine vision applications such as industrial inspection, medical, scientific research, education and so on.

I/O Interface

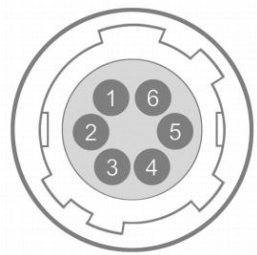

Pin	Definition	Description
1	POWER_IN	Camera external power, +12V DC~+24V DC
2	Line0+	Opto-isolated input +
3	Line2	GPIO input/output
4	Line1+	Opto-isolated output +
5	Line0-/Line1-	Line0-: Opto-isolated input - Line1-: Opto-isolated output -
6	GND	PWR GND & GPIO GND

Spectral Response

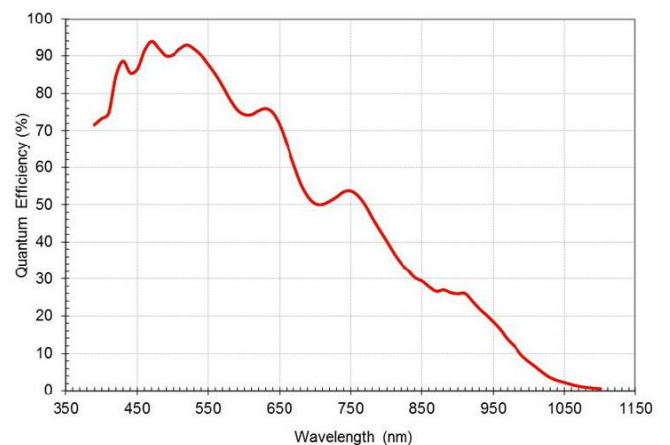

Models

Mono: CK-RNE2-507MI-23RS-IR

Specifications

Model	CK-RNE2-507MI-23RS-IR	
Resolution	2592(H) × 1944(V)	
Sensor	ON AR0522 Rolling shutter CMOS	
Sensor Format	1/2.5"	
Pixel Size	2.2μm × 2.2μm	
Frame Rate	23.3 fps	
ADC	12 bit	
Pixel Bit Depth	8 bit, 12 bit	
Mono/Color	Mono, NIR	
Pixel Formats	Mono8 / Mono12	
SNR	40.03 dB	40.2 dB
Exposure Time	Standard: 20μs ~ 1s, Actual Steps: 1 row period	
Gain	0dB ~ 23.6dB; Default: 0dB, Steps: 0.1dB	
Binning	-	
Decimation	-	
Synchronization	Hardware trigger, software trigger	
Acquisition Control	Continuous, Software trigger, Hardware trigger	
Reverse X/Y	Reverse X/Y	
I/O Interface	1 input and 1 output with opto-isolated, 1 programmable GPIO	
Data Interface	GigE	GigE PoE
Power Supply	12VDC-10% ~ 24VDC+10% supplied via the camera's Hirose connector PoE is optional (Power over Ethernet, IEEE802.3af compliant)	
Typical Power	2.02W @ 12VDC	2.02W @ 12VDC, 2.49W @ PoE
Operating Temp.	0°C ~ +45°C	
Storage Temp.	-20°C ~ +70°C	
Operating Humidity	10% ~ 80%	
Lens Mount	C / CS	
Dimensions	No PoE: 29(W) × 29(H) × 29(L) mm (without lens adapter or connectors) PoE: 29(W) × 29(H) × 40.3(L) mm (without lens adapter or connectors)	
Weight	No PoE: 65 g; PoE: 75 g	
Software	CKVisionBuilder or third-party software meeting with GigE Vision Protocol	
OS	32bit / 64bit Windows, Linux, Mac OS	



Technical Drawing

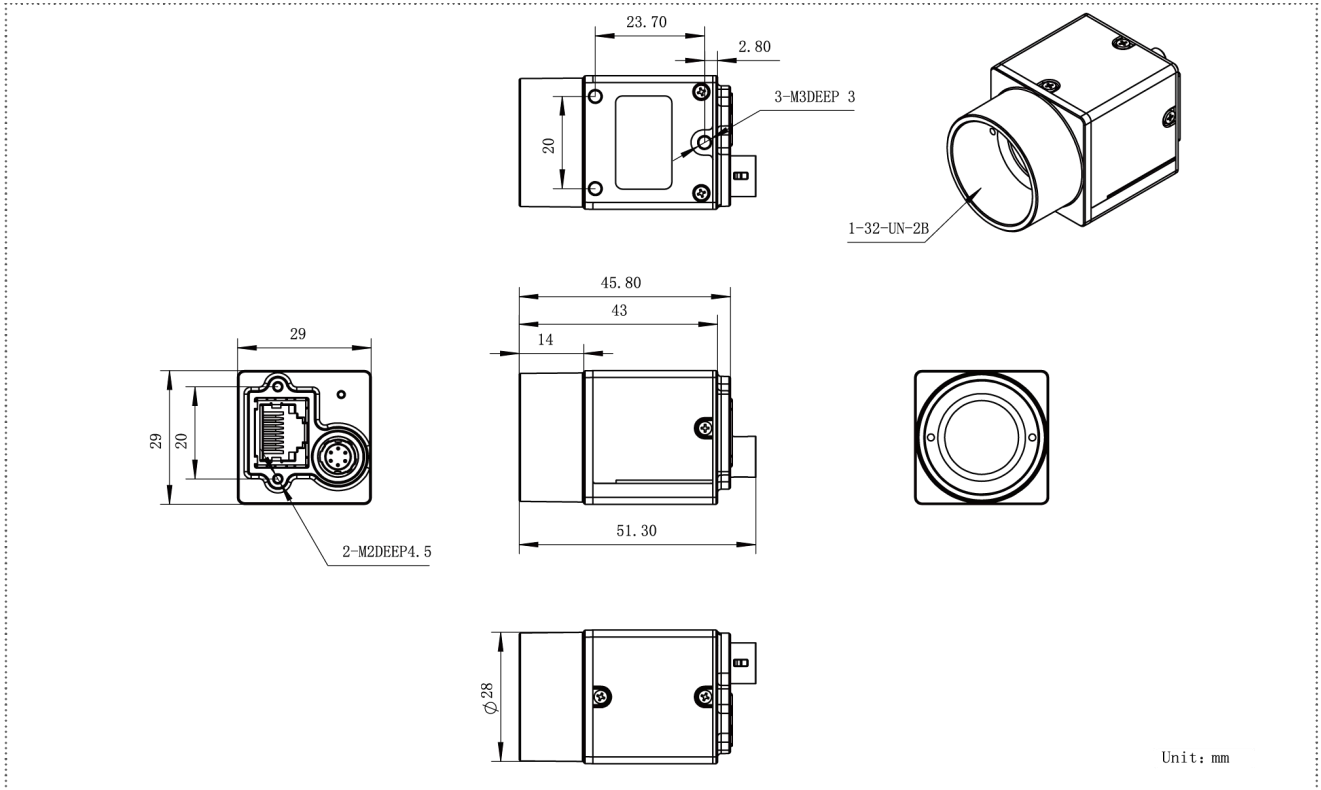

Size A No PoE

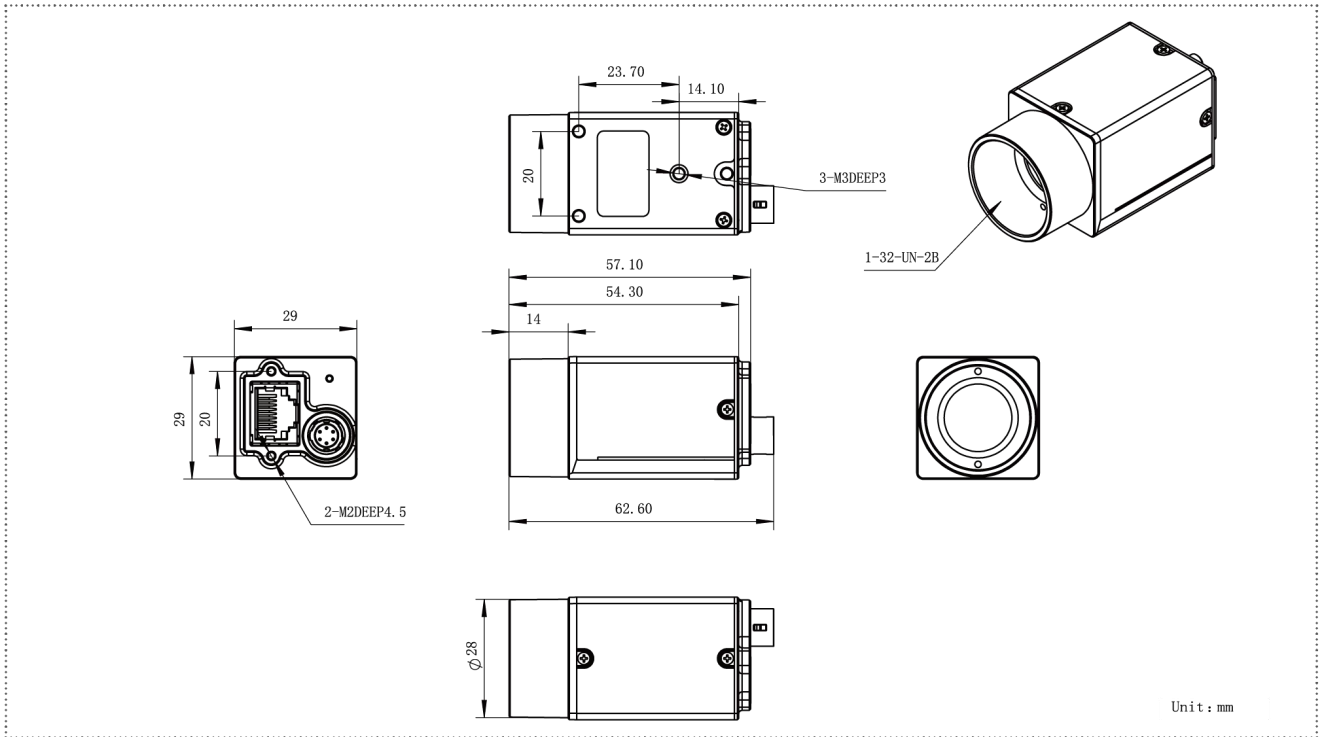

Size B PoE

